

Data Sheet for Angle Sensors



Optical Encoders

Series MHL40



- Optical resolution 10 bis 5000 pulses per revolution
- Metal housing, ball bearing
- 40mm housing diameter
- 6, 8, 10, 12 mm shaft diameter
- Output: NPN, open collector, linedriver, push pull
- 2m signal cable

The MHL spring plate fastening reduces the influences on the MHL40 of shafts with radial and axial shaft eccentricities. The robust design of the MHL40 has proven itself for many years and in hundreds of applications on the market. Where high reliability and longevity are required, the MHL40 is a recommendation.

Electrical Data	Push Pull "B"	Open Collector "K"	Voltage Output "NPN"	Line Driver "N"
Output channels	A, B, Z			A, A/, B, B/, Z, Z/
Number of pulses	10..5000 pulses per rev. (other pulses per revolution on request)			
Output voltage high	Residual voltage 0.4 VDC	Residual voltage max. 0.4 VDC	Residual voltage max. 0.4 VDC	Output voltage min. 2.5 VDC
Output voltage low	Output voltage VSUP 5 VDC: min. VSUP -2.0 VDC Output voltage VSUP 12..24 VDC: min. VSUP-3.0 VDC			Residual voltage max. 0.5 VDC
Limit frequency	300 kHz			
Supply voltage	12..24 VDC ±5 % 5 VDC ±5 %			
Current consumption (no load)	≤ 80 mA		≤ 50 mA	
Output load	(High) max. 30 mA (Low) max. 10 mA	max. 30 mA	max. 10 mA	(High) max. -20 mA (Low) max. 20 mA
Insulation voltage 1.)	≥ 100 MOhm @ 500 VDC			
Insulation resistance 1.)	750 VAC (1 min.)			
Output electronics	Push Pull	Open Collector	Voltage output NPN	Linedriver
Switch-on delay	max. 1 µs			max. 0.5 µs

Data Sheet for Angle Sensors

Optical Encoders

Series MHL40

Mechanical and Environmental Data, Miscellaneous

Mechanical angle of rotation/stroke 1.)	360° without stop
Bearing	Ball bearing
Max. operational speed	5000 rpm
Operational torque @ RT 1.) 2.)	≤ 0.4 Ncm
Operating temperature range	-10..+70 °C
Storage temperature range	-25..+85 °C
Protection grade (IEC 60529) standard	IP50
Vibration (IEC 68-2-6, Test Fc)	10..55 Hz (1 min.); 1.5 mm; each 2 h in X, Y, Z
Shock (IEC 68-2-27, Test Ea)	max. 50G
Housing diameter	40 mm
Housing depth	32 mm
Shaft diameter	Applicable for 6, 8, 10, 12 mm shaft diameter
Shaft type	Solid shaft
Max. radial load	< 19.61 N
Max. axial load	< 9.81 N
Connection type	Standard: round cable 2 m, Ø5 mm Option: 250 mm, Ø5 mm signal cable with plug (standard: 6 pol., linedriver: 8 pol.)
Connection position	Radial
Sensor mounting	Threaded holes in the sensor front (screws not included in delivery) or bracket
Mass	app. 120 g
Fastening parts included in delivery	Bracket included
Material shaft	Stainless steel
Material housing	Aluminium
Material disc	Plastic
Immunity ESD	± 4 kV (CE standard)

1.) According IEC 60393

2.) Determined by climatic conditions according to IEC 68-1, para. 5.3.1 without load collectives

Data Sheet for Angle Sensors

Optical Encoders

Series MHL40

Order Code

Description	Selection: standard=black/bold, possible options=grey/cursive						
Series	MHL40						
For shaft diameter:							
Ø6 mm		6					
Ø8 mm		8					
<i>Option Ø10 mm</i>		<i>10</i>					
<i>Option Ø12 mm</i>		<i>12</i>					
Resolution in pulses per revolution:							
<i>Option 10 ppr.</i>			<i>10</i>				
<i>Option 50 ppr.</i>			<i>50</i>				
<i>Option 100 ppr.</i>			<i>100</i>				
<i>Option 256 ppr.</i>			<i>256</i>				
360 ppr.			360				
<i>Option 500 ppr.</i>			<i>500</i>				
1000 ppr.			1000				
1024 ppr.			1024				
<i>Option 1200 ppr.</i>			<i>1200</i>				
<i>Option 1500 ppr.</i>			<i>1500</i>				
<i>Option 1800 ppr.</i>			<i>1800</i>				
<i>Option 2000 ppr.</i>			<i>2000</i>				
<i>Option 2048 ppr.</i>			<i>2048</i>				
<i>Option 2500 ppr.</i>			<i>2500</i>				
<i>Option 3000 ppr.</i>			<i>3000</i>				
3600 ppr.			3600				
<i>Option 5000 ppr.</i>			<i>5000</i>				
Supply voltage:							
12..24 V				1224			
5 V				5			
Output signal:							
<i>Option A+B</i>					<i>B</i>		
A+B+Z					BZ		
Output electronics:							
Push Pull						B	
<i>Option open collector</i>						<i>K</i>	
<i>Option voltage output</i>						<i>NPN</i>	
<i>Option line driver (output voltage 5V/DC)</i>						<i>N</i>	
Housing options:							
Without through-hole, blind hole depth 27 mm							A
<i>Option with through-hole</i>							<i>B</i>
Electrical Connection (radial):							
Round cable 2 m cable length							-
<i>Option round cable with plug (0,25 m cable length)</i>							<i>ST</i>
<i>Option round cable user defined cable length</i>							
<i>[x,xx meter] without plug</i>							<i>CVRX,XX</i>
<i>Option round cable user defined cable length</i>							
<i>[x,xx meter] with plug</i>							<i>CVRX,XX ST</i>

Order example MHL40

Requirement:

Shaft diameter 6 mm, resolution 360 pulses per revolution, supply voltage 5 V, 2 channels A+B and Index, output electronics Push Pull, 2 m signal cable length

Example for order code: MHL40 6 360 5 BZ B

Data Sheet for Angle Sensors

Optical Encoders

Series MHL40

For higher quantities or on-going demand, additional options are available as described below

For example:

- Other resolutions
- Special cable length
- Special cable and connector design

Technical Drawing

Without through-bore option A

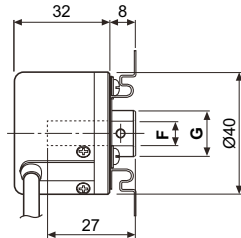
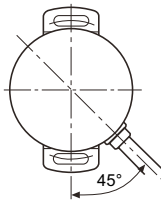

With through-bore option B

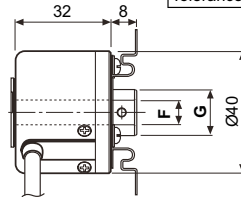
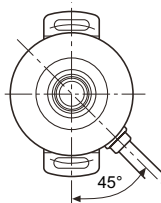

F	Ø6	Ø8	Ø10	Ø12
G	Ø15		Ø17	
Tolerance	+0.015 0			

Dimensions in mm

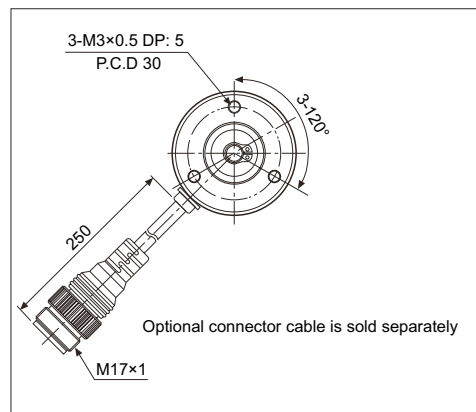
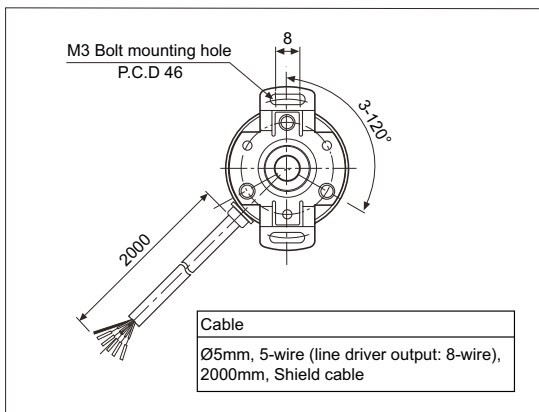
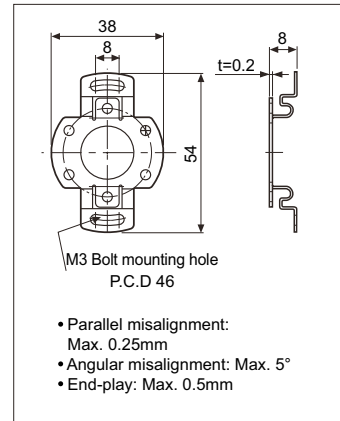

Totem pole output / NPN open collector output / Voltage output

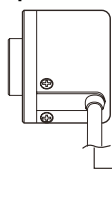

- Black: OUT A
- White: OUT B
- Orange: OUT Z
- Brown: +V (5VDC, 12-24VDC ±5%)
- Blue: GND (0V)
- Shield: F.G.

Line driver output

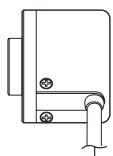

- Black: OUT A
- Red: OUT \bar{A}
- White: OUT B
- Gray: OUT \bar{B}
- Orange: OUT Z
- Yellow: OUT \bar{Z}
- Brown: +V (5VDC, 12-24VDC ±5%)
- Blue: GND (0V)
- Shield: F.G.

The metal case and shield wire of encoder should be grounded (F.G.).
Unused wires must be insulated.

Totem pole output / NPN open collector output / Voltage output

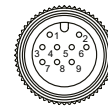

Totem pole output/ NPN open collector output/ Voltage output			Line driver output		
Pin No	Function	Cable color	Pin No	Function	Cable color
①	OUT A	Black	①	OUT A	Black
②	OUT B	White	②	OUT \bar{A}	Red
③	OUT Z	Orange	③	+V	Brown
④	+V	Brown	④	GND	Blue
⑤	GND	Blue	⑤	OUT B	White
⑥	F.G.	Shield	⑥	OUT \bar{B}	Gray
			⑦	OUT Z	Orange
			⑧	OUT \bar{Z}	Yellow
			⑨	F.G.	Shield

F.G. (field ground): It should be grounded separately.

Data Sheet for Angle Sensors

Optical Encoders

Series MHL40

Output Diagram

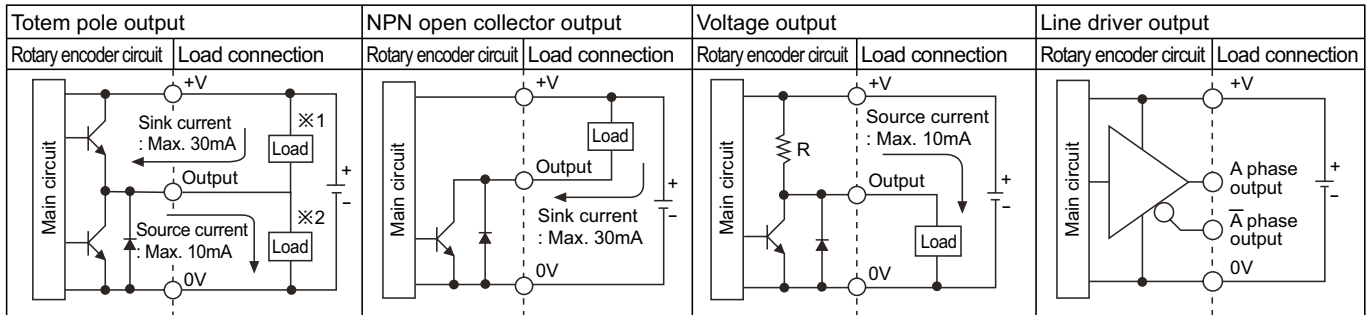

Totem pole output type can be used for NPN open collector output type (※1) or Voltage output type (※2).
 All output circuits of A, B, Z phase are same. (line driver output is A, \bar{A} , B, \bar{B} , Z, \bar{Z})

Output Waveform

Totem pole output /
 NPN open collector output /
 Voltage output

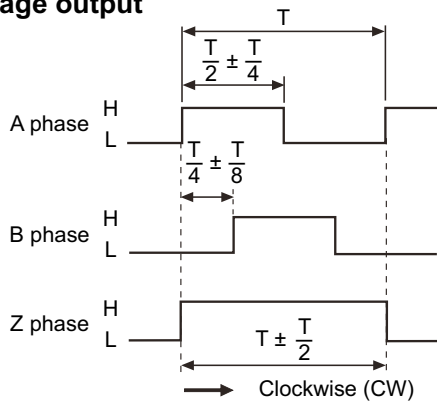

Line driver output

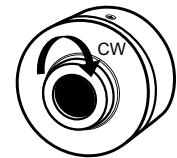
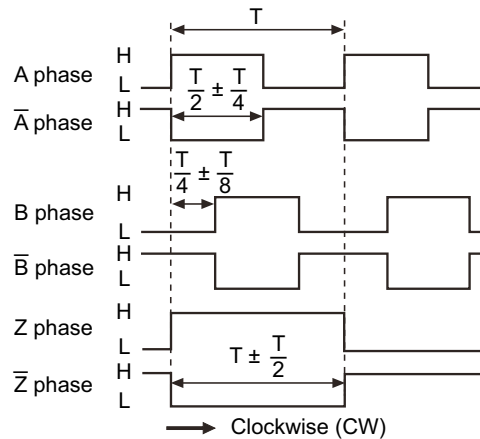

※Z reverse phase output is optional.